

Power Assistance Device

Shares Payload for a **Safer Workplace**

CURRENTLY

Back pain accounts for **over half** of work-related injuries.



64% of workers in the Manufacturing Industry are over the age of 40.

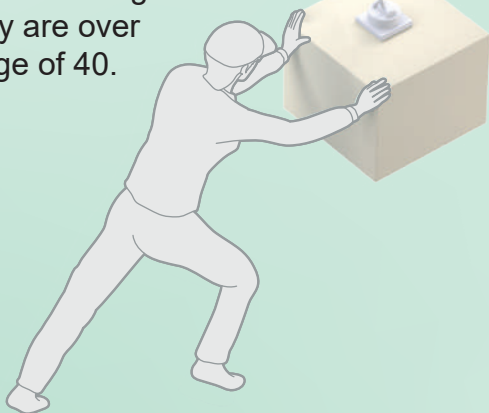

NEW SOLUTION



SAFE OPERATION

The center of gravity is close to the operator and there are handles mounted to the joints for increased control. This allows for simple and safe operation without coming in contact with moving parts.

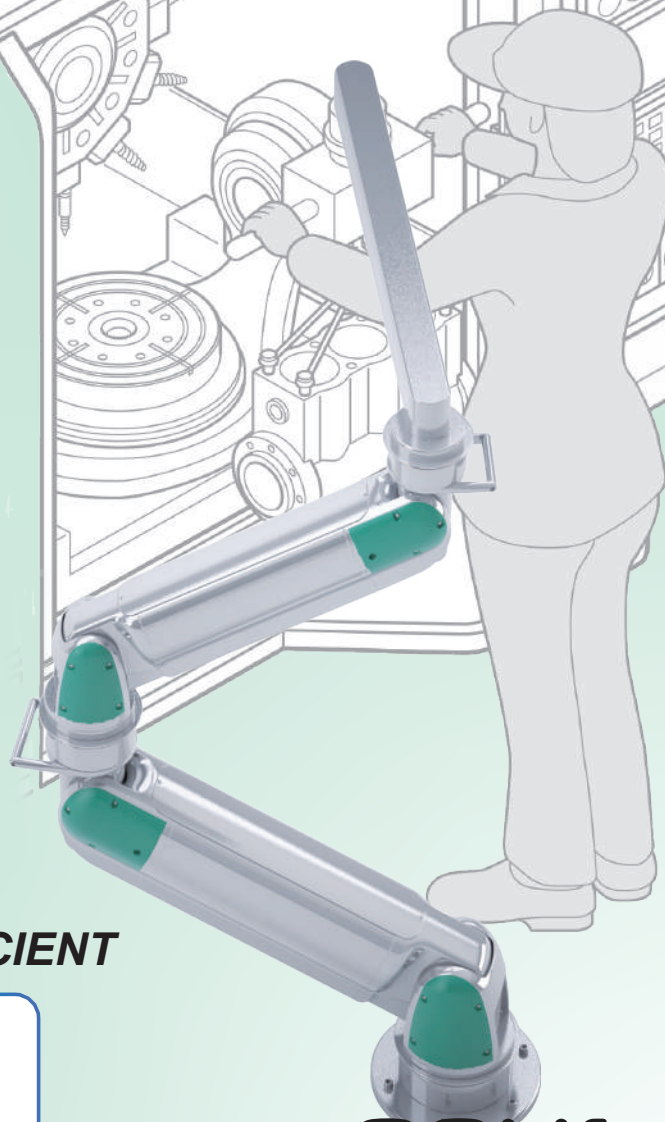

BENEFITS

COMPACT DESIGN



Compact design that can be folded and stored even with multi-axis specifications.

ENERGY EFFICIENT



The system works using +0.05 MPa to 0.7MPa air pressure.

PAW Series
PowerArm

 **TOYOTA TSUSHO**
CANADA, INC.

CKD
Corporation

Movable Range Specifications

WIDER RANGE OF MOVEMENT AND MOTION

Extension arms (extension axes) can be used for multi-axis specification types to enable an even wider range of motion. Freely combine single-axis and multi-axis specifications to suit your applications and worksites.

· With multi-axis

Arm	Movable range (mm)	
	Vertical (mm)	Horizontal (mm)
Combination of $\phi 80$ + SCARA arm	520	1200
Combination of $\phi 100$ + SCARA arm	580	1400
Combination of $\phi 125$ + SCARA arm	650	1600
Combination of $\phi 80$ + $\phi 100$	1100	1300
Combination of $\phi 100$ + $\phi 125$	1230	1500
Combination of $\phi 80$ + $\phi 100$ + SCARA arm	1100	2000
Combination of $\phi 100$ + $\phi 125$ + SCARA arm	1230	2300
Combination of $\phi 80$ + $\phi 100$ + $\phi 125$	1750	2100

Note: Horizontal movable range is the maximum value at the descending edge of the vertical movable range. See the external dimensions for more information on the movable range.

Movable range

· With single-axis

Bore size (mm)	Movable range (mm)
	Vertical (mm)
$\phi 80$	520
$\phi 100$	580
$\phi 125$	650

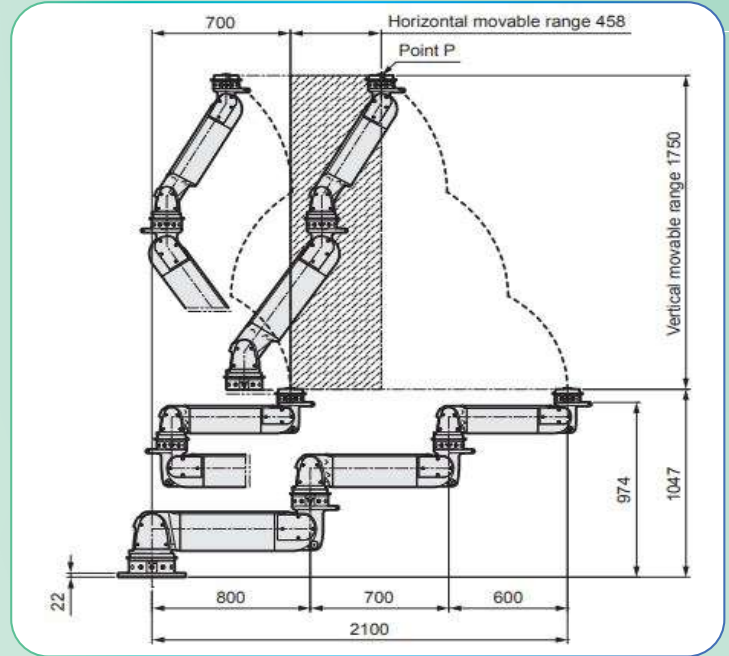

Reach and Load Capacity Specifications

ARM VARIATIONS TAILORED TO THE SPECIFIC WORKPIECE

The arm can be selected from 3 types according to the work piece load.

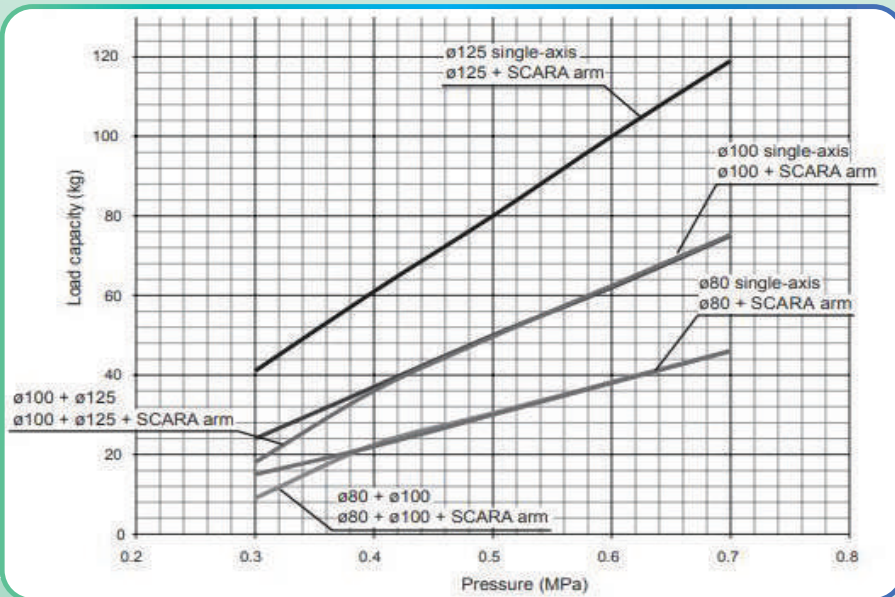

WIDE RANGE CAPACITY

Three types of arms can be selected with respect to the work load.

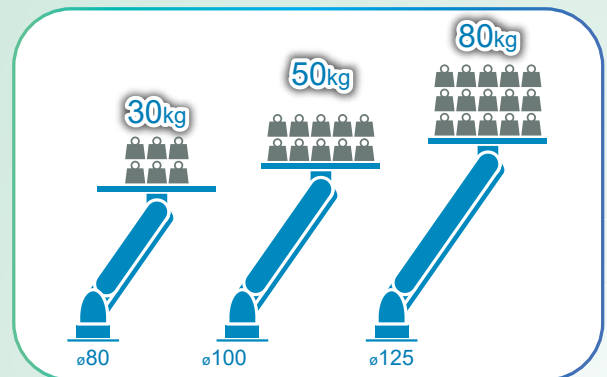

For More Information, Please Contact:

Jake Assadourian, Outside Sales Representative

Phone: 519-240-2190 E-Mail: Jake_Assadourian@ttci.ca

Scan here to check us out online!

